

PATRON PROMAT PROPANE CONSTRUCTION HEATERS 10T, 25T, 50T OWNER'S MANUAL

HEATER SIZES 41,000 - 85,000 -190,000 BTU/Hr

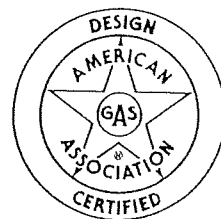
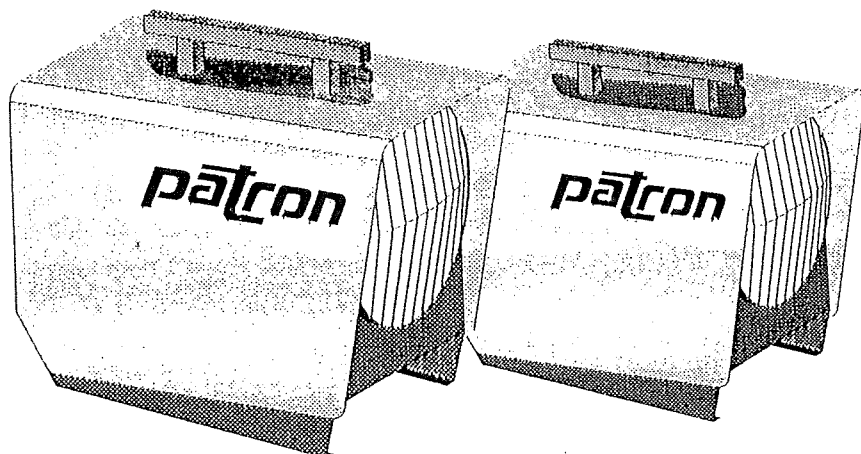

GENERAL HAZARD WARNING

FAILURE TO COMPLY WITH THE PRECAUTIONS AND INSTRUCTIONS PROVIDED WITH THIS HEATER, CAN RESULT IN DEATH, SERIOUS BODILY INJURY AND PROPERTY LOSS OR DAMAGE FROM HAZARDS OF FIRE, EXPLOSION, BURN, ASPHYXIATION, CARBON MONOXIDE POISONING, AND/OR ELECTRICAL SHOCK.

ONLY PERSONS WHO CAN UNDERSTAND AND FOLLOW THE INSTRUCTIONS SHOULD USE OR SERVICE THIS HEATER

IF YOU NEED ASSISTANCE OR HEATER INFORMATION SUCH AS AN INSTRUCTIONS MANUAL, LABELS ETC. CONTACT THE DISTRIBUTOR



WARNING: FIRE, BURN, INHALATION, AND EXPLOSION HAZARD. KEEP SOLID COMBUSTIBLES, SUCH AS BUILDING MATERIALS, PAPER OR CARDBOARD, A SAFE DISTANCE AWAY FROM THE HEATER AS RECOMMENDED BY THE INSTRUCTIONS. NEVER USE THE HEATER IN SPACES WHICH DO OR MAY CONTAIN VOLATILE OR AIRBORNE COMBUSTIBLES, OR PRODUCTS SUCH AS GASOLINE, SOLVENTS, PAINT THINNER, DUST PARTICLES OR UNKNOWN CHEMICALS



WARNING NOT FOR HOME OR RECREATIONAL VEHICLE USE

We cannot anticipate every use which may be made of our heaters. CHECK WITH YOUR LOCAL FIRE SAFETY AUTHORITY IF YOU HAVE QUESTIONS ABOUT APPLICATIONS

This heater is designed and approved for use as a construction heater under ANS Z83.7b.-1993 Constr. Htr. Other standards govern the use of fuel gases and heat producing products in specific applications.

Your local authority can advise you about these

SAFETY INFORMATION

IMPORTANT: Read this manual completely and carefully before assembling, operating or servicing this heater. Improper use can cause serious injury or death from fire, explosion, electrical shock or carbon monoxide poisoning.

KEEP THIS MANUAL FOR FURTHER REFERENCE.

Carbon monoxide poisoning starts with symptoms similar to a common flu, with headache, nausea or dizziness.

If you notice these signs, get fresh air at once !

This may be caused by non-sufficient ventilation or the heater may not operate properly. Have heater serviced immediately and provide proper ventilation.

Make sure you read and understand all Warnings.

This heater is intended to be used for temporary heating of buildings under construction, alteration or repair

Do not use in occupied dwellings or outdoors

Do not use heater where gasoline, paint thinner or other highly flammable vapors or combustible dust are present

Check heater for damages before each use. Never use a damaged heater.

Do not block air inlet or outlet of heater

Keep children and animals away from heater

Use only in well vented areas

Note: this heater is thermostat controlled. When plugged, heater may start anytime

Never move, handle or service an operating, plugged in or hot heater

In handling, storing or using liquid Propane, follow all instructions given in this manual and all local and other applicable codes of safety

Do not attach ductwork to front or rear of heater

Only plug to three-hole grounded electric outlet

Unplug heater when not in use

INSTALLATION OF PROPANE SUPPLY

WARNING

ALL GAS CONNECTIONS MUST BE CHECKED FOR LEAKS AFTER INSTALLATION OR SERVICING. ALL LEAKS MUST BE CORRECTED AT ONCE.

THE LPG CONTAINER MUST BE LOCATED AT A MINIMUM DISTANCE OF 6 FEET AWAY FROM THE HEATER.

NEVER POINT THE HOT AIR OUTLET OF THE HEATER TOWARD ANY LP-CONTAINER CLOSER THAN 20 FEET.

1. Provide propane supply. Use 20 pound or larger tanks only. Always use tanks in an upright position. See ANSI/NFPA 58 and applicable local standards for Storage and Handling of Liquefied Petroleum Gases.
2. Connect the POL fitting provided with the hose assembly to propane tank. Tighten POL fitting firmly by turning counterclockwise with a wrench. See that the regulator vent is pointing down to protect vent from water. NEVER USE ANY OTHER REGULATOR THAN THE ORIGINAL ONE SUPPLIED. NEVER ALTER PRESSURE SETTING FROM PRE-SET 15 PSI.
3. Connect gas hose to gas inlet connector in the rear panel of the heater. Tighten firmly with a wrench.
4. Open propane supply valve SLOWLY. Do not start heater.
5. Check all connections by applying mixture of liquid soap and water to all joints. **BUBBLES FORMING SHOW A LEAK. CLOSE SUPPLY VALVE AND CORRECT LEAK AT ONCE !**

WARNING

NEVER USE AN OPEN FLAME FOR LEAK TESTING !

6. Close propane supply valve

VENTILATION

Provide a fresh air opening of the following minimum sizes:

For PROMAT 10 T : min. 1,5 square feet

For PROMAT 25 T : min. 2,5 square feet

For PROMAT 50 T : min. 4.0 square feet

WARNING

FAILURE TO PROVIDE PROPER FRESH AIR VENTILATION CAN RESULT TO CARBON MONOXIDE POISONING. PROVIDE VENTILATION BEFORE RUNNING HEATER AND DURING THE WHOLE HEATING PERIOD.

STORAGE

Close tank valve and disconnect heater from propane supply tank.

Store heater in a dry, clean and safe place out of reach of children and unqualified people.

Store Propane tanks in a safe place. Follow all local safety codes applicable. In the absence of local codes, store according to chapter 5 of the Standard for the Storage and Handling of Liquefied Petroleum Gases, ANSI/NFPA 58.

OPERATION

REVIEW AND UNDERSTAND ALL WARNINGS IN THIS MANUAL. THEY ARE ESSENTIAL FOR SAFE USE OF THE HEATER. FOLLOW ALL LOCAL CODES.

TO START HEATING:

MINIMUM AMBIENT TEMPERATURE FOR OPERATING THE HEATER IS -20° F

1. Make sure that you have read, understood and followed all installation, ventilation and safety instructions in this manual.
2. Place the heater on a stable and level surface. Make sure that no explosive or combustible fumes or dust are present. Protect heater from strong drafts or wind. See that the heater is not exposed to water spray, rain or dripping water.

MINIMUM CLEARANCES FROM COMBUSTIBLE MATERIALS:

OUTLET 9 FEET SIDES 2 FEET TOP 6 FEET REAR 2 FEET

3. Plug power cord of heater into a three-hole, grounded 110-120 Volt 60 Herz outlet. If an extension cord is used, it must be UL-listed. Up to 50 feet long, the extension cord must be rated 18 AWG, 50 to 100 feet long 16 AWG.
4. Open propane supply valve slowly. NOTE: Opening the valve too quickly causes the excess flow safety valve to close. Should this happen, close propane supply valve and open again slowly.
5. Set the ambient thermostat to a temperature above the ambient room temperature by turning the knob. NOTE: The heater will start only if the thermostat "calls for heat" meaning that it is set to higher than prevailing ambient temperature.
6. Push the main switch into position I=HEAT. The fan will now start turning to provide pre-purge air. After appr. 20 seconds, the heater will ignite and start heating. NOTE: If the heater fails to start, turn switch to 0=OFF, wait for 10 seconds for automatic safety reset, and turn switch back to position I.

THE HEATER WILL NOW OPERATE AUTOMATICALLY, CONTROLLED BY THE AMBIENT THERMOSTAT. MAKE SURE THERE IS ENOUGH PROPANE IN THE TANK FOR CONTINUOUS USE.

TO STOP HEATING

1. Close propane supply valve on propane tank.
2. Wait until the heater stops after using all gas left in supply hose.
3. Push switch to position 0=OFF.
4. Unplug the power supply cable.

TO USE AS A VENTILATOR ONLY

1. Do not connect to propane supply
2. Plug heater to 110-120 Volt 60 Hz mains as above.
3. Use main switch for II=VENT and 0=OFF.
4. Unplug heater after use.

MAINTENANCE

WARNING

NEVER SERVICE HEATER WHILE IT IS PLUGGED IN, CONNECTED TO PROPANE SUPPLY, RUNNING OR HOT. SEVERE BODILY INJURE OR ELECTRIC SHOCK MAY OCCUR.

ONLY QUALIFIED PERSONS ARE ALLOWED TO OPEN HEATER FOR SERVICE

GENERAL

1. Keep heater clean. Use pressurized air to blow fan blades clean. NOTE: Use moderate pressure to avoid damage to air flow sail switch and fan blades.
2. Inspect heater before and after each use.
3. The bearings of the fan motor are permanently lubricated and sealed. No additional lubrication is needed.
4. Check hose-regulator assembly before each use. Replace worn or damaged hose immediately. Replace with original PATRON PROMAT hose assembly only
5. Have heater inspected yearly by a qualified service person.
6. Always use original spare parts obtained from your local PROMAT dealer.

MAIN PARTS OF THE HEATER

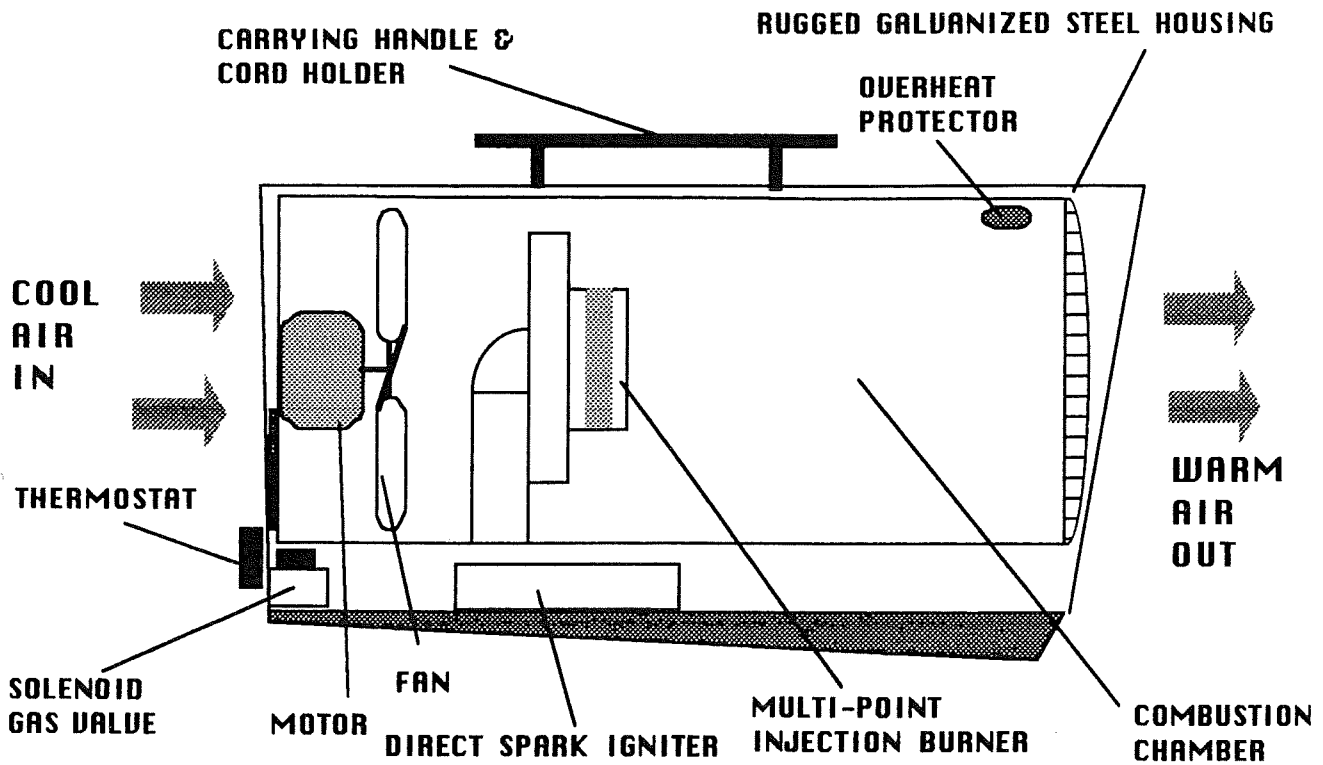

REAR PANELS & CONTROLS

10T, 20T

50T

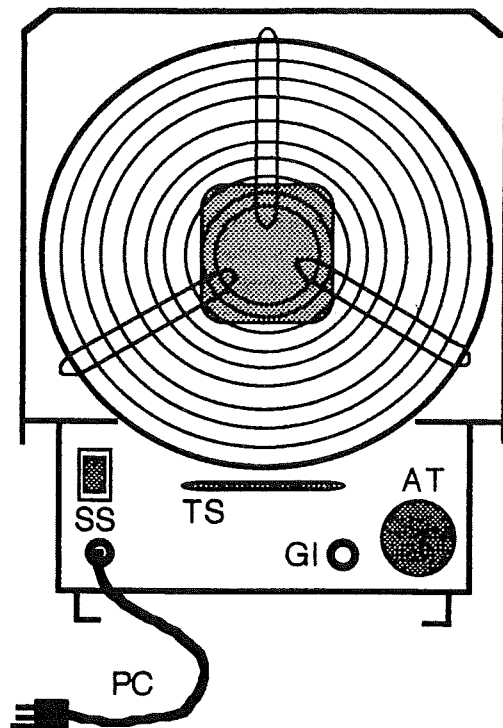
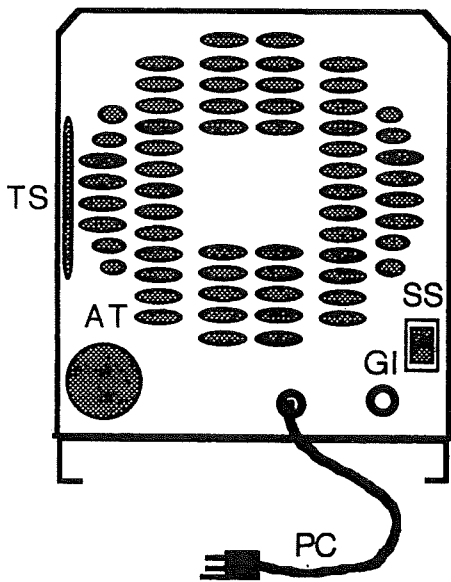

- SS = Selector Switch
- PC = Power Cord
- AT = Ambient Thermostat knob
- TS = Thermostat Sensor
- GI = Gas Inlet

THEORY OF OPERATION

THE FAN

IS TURNED BY THE MOTOR. AIR IS PUSHED INTO THE COMBUSTION CHAMBER TO PROVIDE SECONDARY COMBUSTION OXYGEN, AND HEATED UP BY THE CLEAN-BURNING FLAME

THE BURNER

IS A MULTI-POINT INJECTION PRE-MIX BURNER. PRIMARY AIR IS MIXED WITH COMBUSTION GAS, AND EJECTED THROUGH THE MICRO-SIZE INJECTION HOLES INTO THE COMBUSTION CHAMBER. THIS SYSTEM ENSURES CLEANEST POSSIBLE BURNING OF PROPANE GAS WITH MINIMUM CO AND MAXIMUM EFFICIENCY

THE IGNITION CONTROL / SAFETY SYSTEM

PROVIDES POSITIVE DIRECT-SPARK IGNITION OF PRE-MIXED AIR/GAS MIXTURE. THE CONTROLS INCLUDE AMBIENT TEMP. CONTROL, AIR FLOW CHECK SYSTEM AND OVERHEAT PROTECTION. THE GAS REGULATOR/HOSE ASSEMBLY IS EQUIPPED WITH EXCESS FLOW VALVE TO PROVIDE PROTECTION AGAINST HOSE DAMAGE.

THE FUEL

VAPORIZED PROPANE ONLY ! FUEL IS PROVIDED THROUGH THE REGULATOR - HOSE ASSEMBLY DELIVERED WITH THE HEATER. AN ELECTRIC SOLENOID VALVE CONTROLLED BY THE IGNITION CONTROL SYSTEM OPENS AND CLOSES THE GAS FLOW.

SEQUENCE OF OPERATION

AFTER BEING PLUGGED INTO 110-120 V 60 HZ CURRENT AND A PROPANE SOURCE, THE OPERATION OF THE HEATER IS AS FOLLOWS:

- 1 THE SWITCH IS MOVED TO POSITION "HEAT". IF THE SETTING OF THE AMBIENT THERMOSTAT IS HIGHER THAN AMBIENT TEMP., THE FAN WILL START.
- 2 THE SAIL SWITCH PROVES THAT THERE IS ENOUGH AIR FLOW. IF SO, THE DIRECT IGNITION SYSTEM IS ACTIVATED
- 3 THE DSI OPENS THE SOLENOID VALVE AND GIVES SPARKS TO IGNITE. IF FAILED, A RETRIAL WILL FOLLOW
- 4 AFTER SUCCESSFUL IGNITION, THE HEATER IS MONITORED BY THREE SEPARATE SYSTEMS: THE FLAME SENSING, AIR FLOW CONTROL AND TEMPERATURE LIMIT SENSOR. SHOULD ANY OF THESE FAIL, THE DSI WILL SHUT OFF THE GAS BY CLOSING THE VALVE
- 5 RESETTING IS ESTABLISHED BY SWITCHING THE POWER OFF FOR 30 SECONDS AND REPEATING THE STARTING PROCEDURE

SPECIFICATIONS

HEATER TYPE	PROMAT 10T	PROMAT 25T	PROMAT 50T
OUTPUT RATING BTU/HR	40,000	85,000	190,000
WATTS	12,000	25,000	55,000
FUEL CONSUMPTION POUNDS/HR	max. 1.85	max. 4.50	max. 9.00
SUPPLY PRESS.TO REGULATOR MAX PSI	Tank pressure for all sizes		
MIN. FOR ADJUSTMENT PSI	20	20	20
REGULATOR OUTLET PRESSURE PSI	15	15	15
WARM AIR OUTPUT APPROX. CFM	200	280	600
ELECTRIC INPUT	120V/60HZ/3A	120V/60HZ/3A	120V/60HZ/3A
IGNITOR POINT GAP INCHES	1/8 "	1/8 "	1/8 "

PATRON PROMAT PARTS LIST
 TYPES 10T & 25T

ITEM PART NO DESCRIPTION

1	25001	HANDLE
2	25002	MANTLE
3	25003	FRONT PANEL
4	25004	BURNER CHAMBER
5	25005	GRILL
6	25006	BOTTOM PLATE
7	25007	DIRECT SPARK IGNITOR
8	25008	TEMP. LIMIT DEVICE
9	25009	SAIL SWITCH
10	25010	AMBIENT THERMOSTAT
13	25011	TERMINAL BLOCK
14	25012	IGN. & FLAME SENS. ELECTR.
17	25013	TUBE CONNECTOR
18	25014	ORIFICE PROMAT 25 T
	10014	ORIFICE PROMAT 10 T
19	25015	COPPER TUBE
23	25016	TUBE CONNECTOR
24	25017	SOLENOID VALVE
25	25018	HOSE CONNECTOR
30	25019	SELECTOR SWITCH
31	25020	STRAIN RELIEF
32	25021	POWERCORD
33	25022	REAR PANEL
34	25023	FAN MOTOR
35	25024	HUB
36	25025	FAN BLADE PROMAT 25 T
	10025	FAN BLADE PROMAT 10 T
37	25026	NUT&WASHER
38	25027	BURNER HEAD PROMAT 25 T
	10027	BURNER HEAD PROMAT 10 T

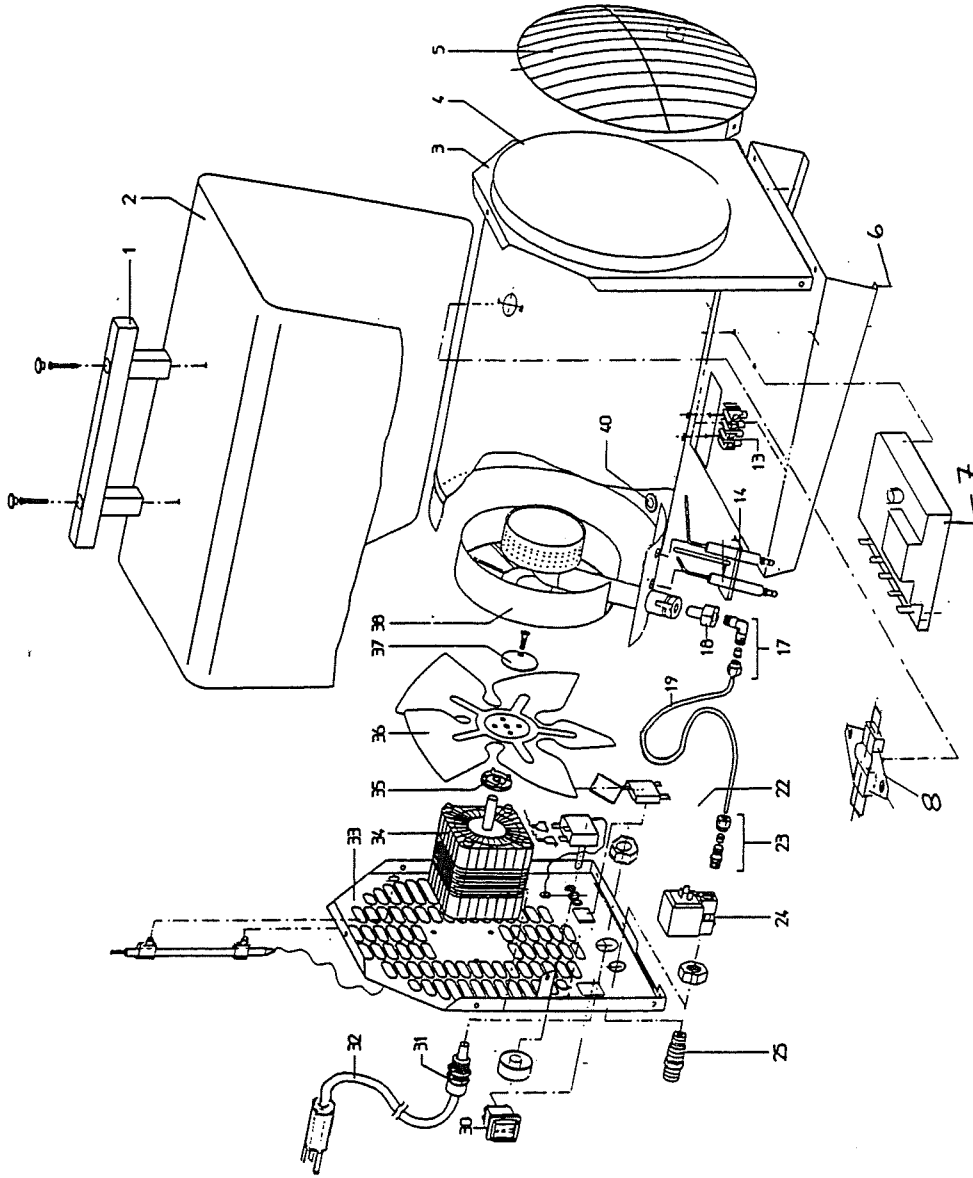

PATRON PROMAT PARTS LIST
TYPE 50T

ITEM PART NO DESCRIPTION

- 1 50001 HANDLE
- 2 50002 MANTLE
- 3 50003 HEAT REFLECTOR
- 4 50004 BURNER CHAMBER
- 5 50005 TEMP.LIMIT DEVICE
- 6 50006 SAIL SWITCH
- 7 50007 DIRECT SPARK IGNITOR
- 8 50008 AMBIENT THERMOSTAT
- 9 50009 GRILL
- 10 50010 IGN. & FLAME SENSOR ELECTR.
- 11 50011 SENSOR CABLE
- 12 50012 IGN. CABLE
- 16 50016 TUBE CONNECTOR
- 17 50017 ORIFICE
- 18 50018 FRONT FOOT
- 19 50019 BOTTOM BOX
- 20 50020 COVER PLATE
- 21 50021 REAR FOOT
- 22 50022 COPPER TUBE
- 24 50024 TERMINAL BLOCK
- 26 50026 TUBE CONNECTOR
- 32 50032 SOLENOID VALVE
- 33 50033 HOSE CONNECTOR
- 37 50037 POWER CORD
- 38 50038 STRAIN RELIEF
- 39 50039 SELECTOR SWITCH
- 42 50042 REAR GRILL
- 43 50043 FAN MOTOR
- 44 50044 HUB
- 45 50045 FAN BLADE
- 46 50046 NUT&WASHER
- 47 50047 BURNER HEAD

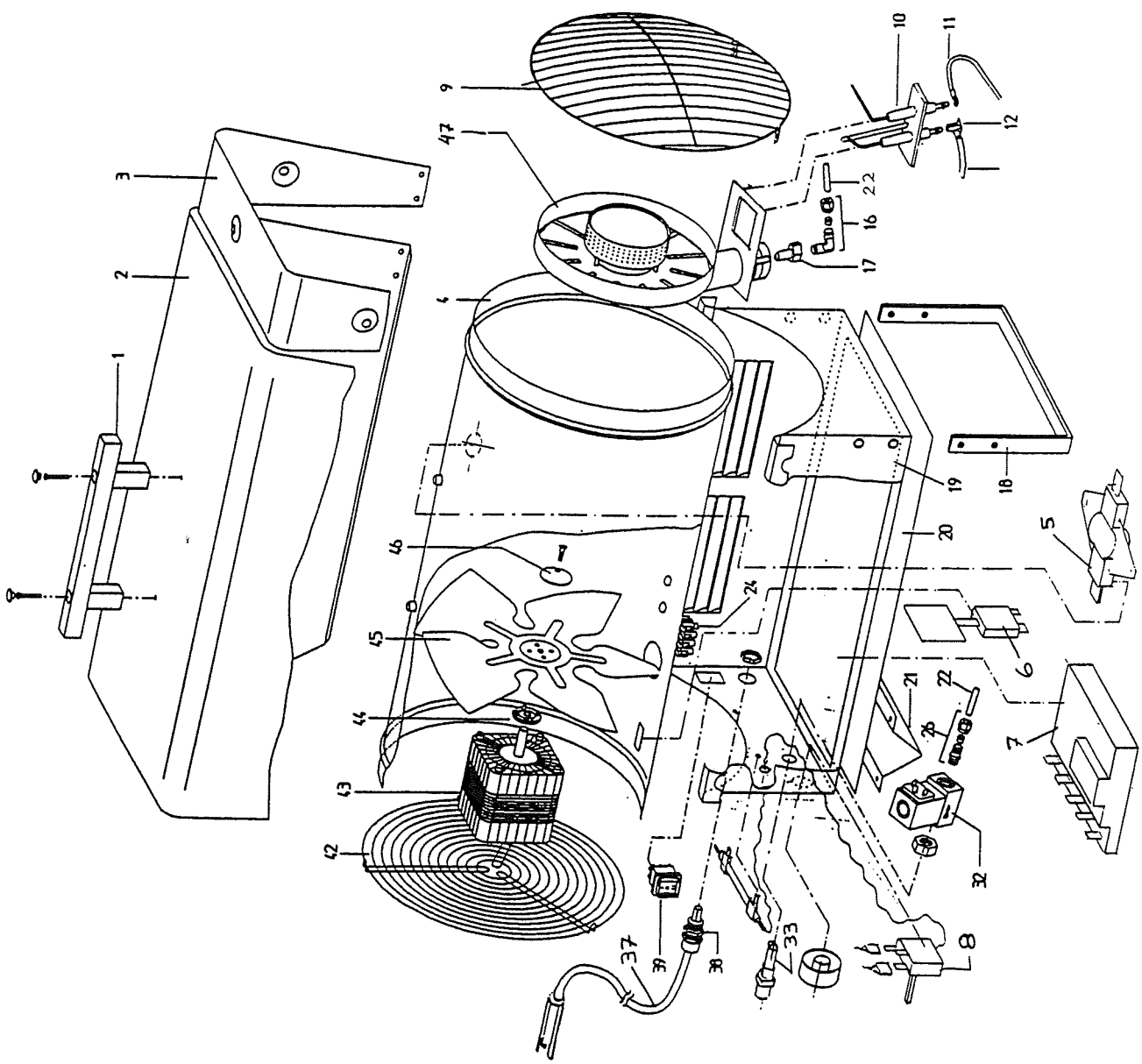

ELECTRICAL WIRING DIAGRAMS FOR LPG FORCED AIR HEATERS PROMAT 10T, 25T AND 50T

CONNECTION DIAGRAM

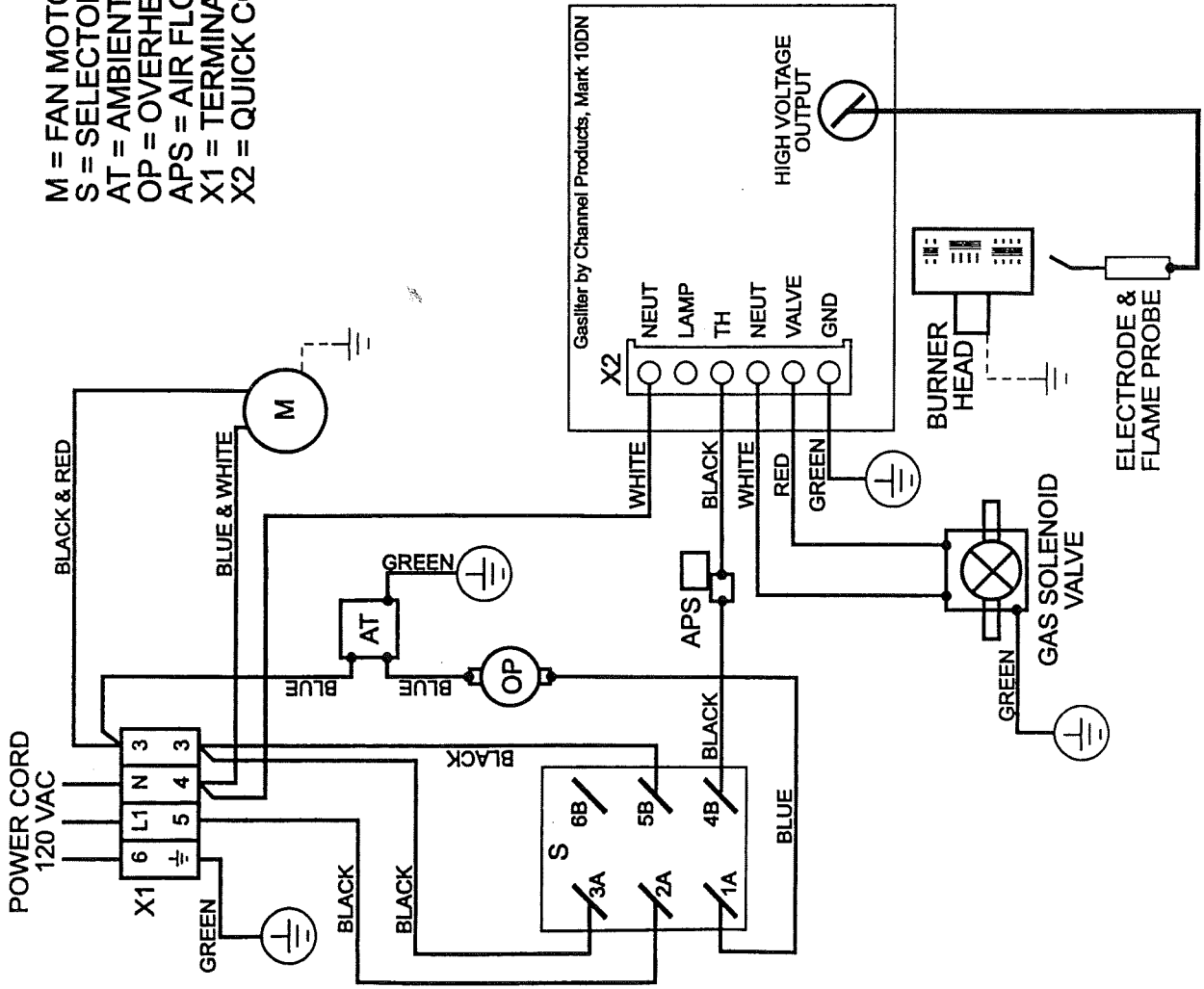

- M = FAN MOTOR
- S = SELECTOR SWITCH
- AT = AMBIENT THERMOSTAT
- OP = OVERHEAT LIMIT SWITCH
- APS = AIR FLOW SENSOR SWITCH
- X1 = TERMINAL BLOCK
- X2 = QUICK CONNECTOR (GASLITER)

LADDER DIAGRAM

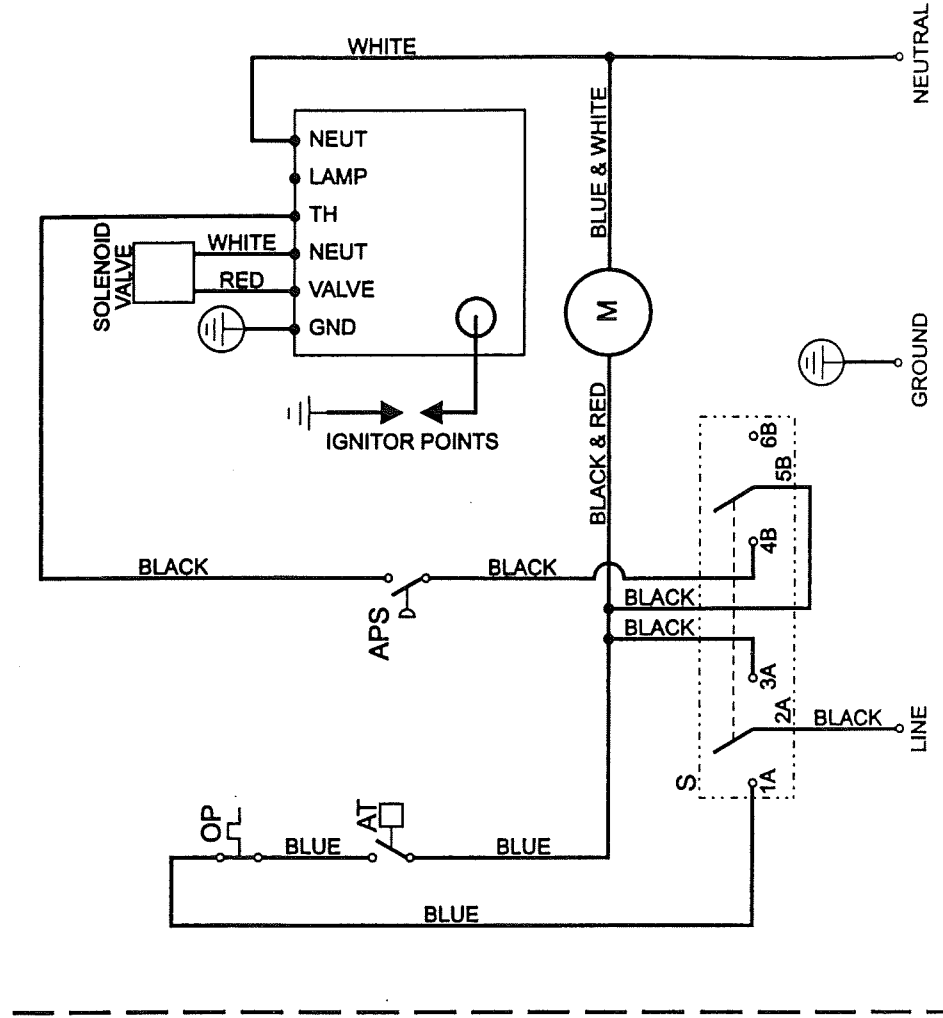

IF ANY OF THE ORIGINAL WIRE AS SUPPLIED WITH THE APPLIANCE MUST BE REPLACED, IT MUST BE REPLACED WITH TYPE 105 °C WIRE OR EQUIVALENT

PATRON PROMAT HEATERS - LIMITED WARRANTY

PATRON PROMAT heater products are professional construction heaters. They are warranted for twenty four (24) months from original date of purchase. The warranty does not cover products modified outside our factory, damage or failure caused by acts of God, abuse, misuse, use on other than rated voltage, abnormal usage, faulty or improper installation, failure to provide recommended maintenance or any repairs other than those provided by an authorized PATRON PROMAT service.

THERE ARE NO OBLIGATIONS OR LIABILITIES ON THE PART OF PATRON PRODUCTS, INC., FOR CONSEQUENTIAL DAMAGES ARISING OUT OF OR IN CONNECTION WITH THE USE OR PERFORMANCE OF THE PRODUCT OR OTHER INDIRECT DAMAGES WITH RESPECT TO LOSS OF PROPERTY, REVENUES, OR PROFIT, OR COST OF REMOVAL, INSTALLATION OR REINSTALLATION.

THIS WARRANTY CONSTITUTES THE EXCLUSIVE REMEDY OF ANY PURCHASER OF EQUIPMENT SOLD BY THE MANUFACTURER AND ITS DEALERS AND DISTRIBUTORS AND IS IN LIEU OF ALL OTHER WARRANTIES, EXPRESS OR IMPLIED.

During the warranty period, PATRON PRODUCTS, INC. will, at it's sole option, repair or replace any defective parts or products returned, freight prepaid, to PATRON PRODUCTS, INC. or such other location as PATRON PRODUCTS, INC. may designate.

Returned products must be packaged carefully, and PATRON PRODUCTS, INC. shall not be responsible for damage in transit. When returning parts, the owner must provide the model number of the product and the nature of difficulty being experienced. This warranty does not oblige PATRON PRODUCTS, INC. to bear the cost of labour in replacing any assembly, unit or component or part thereof, nor does the company assume any liability for secondary charges, expenses of removal or installing, freight or damages. There will be charges rendered for product repair after our warranty period has expired.

Proof of purchase, including date, must accompany request for in-warranty service.

PATRON PRODUCTS, INC.

**2 - 501 Passmore Avenue
Scarborough, ON M1V5G4**

Phone 416-298-3639